

Dismantling original parts

1. Dismantle the original fender, lights and indicators.
2. Remove the inner fender (16) by drilling out the rivets (12).

Montage neuer Heckfender

1. Attach the inner fender to the new "Bobber" fender with the supplied rivets.
2. Mount the new fender to the frame with the original screws (4,5) or the black screws supplied.
3. Replace the original holder of the seat with the supplied holder and fix it to the fender with the original screws.
4. The cables can be re-routed inside with the cable ties.

Tightening torque: 10 to 15 Nm

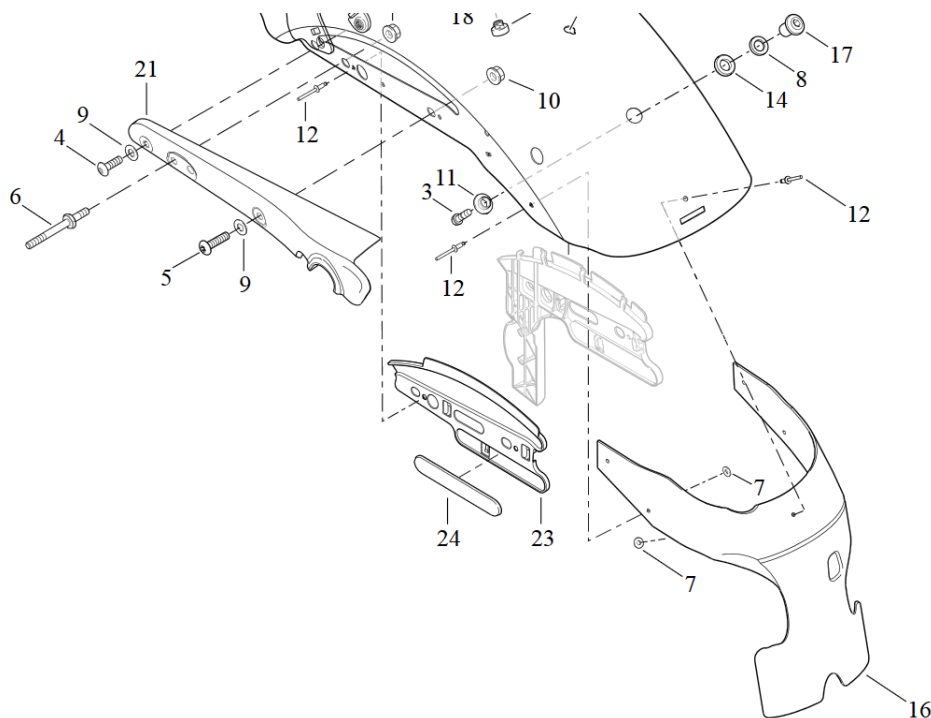

We recommend using a medium-strength screw lock (e.g. LOCTITE 243, blue) for all screws.

! Note !

After assembly, the spring travel must be checked! If necessary, the spring travel must be limited accordingly (spring travel limiter HD-ROD048)!

To mount the fender, it is necessary to remove the original fender incl. licence plate holder and light system. We therefore recommend fitting a side licence plate holder (HD-SPO012) and a 3-in-1 indicator set (e.g. HD-SPO032) incl. holder (HD-SPO022).



Abb. 1 – Mounted fender



Abb. 2 – Fender "Bobber" incl. mounting material